

CHEMINEES PHILIPPE -DIFUSION- MODEL C9-2

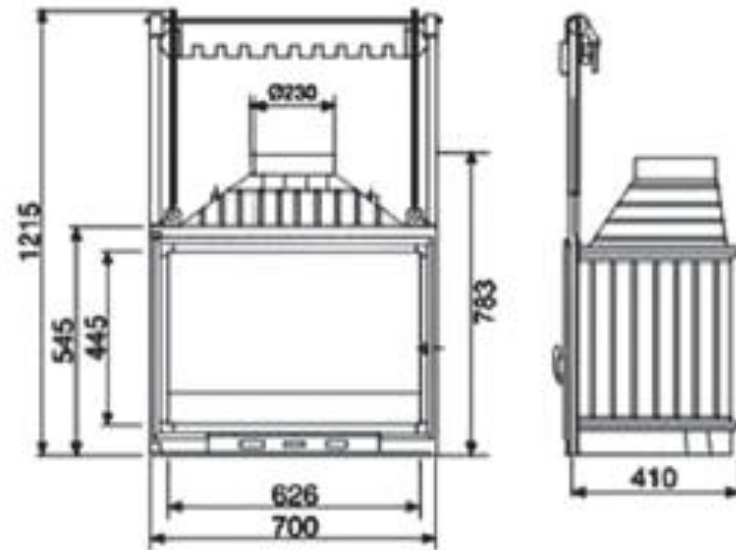

TECHNICAL SPECIFICATIONS

- Thermal Output Kw : 12 Kw
- Efficiency : 72.3 %
- Outlet Dimensions : 230 mm
- Weight : 194 Kg

- **Dumper installed**