

MORETTIDESIGN®



CLESSIDRA GLASS A9

9,0 kw



TECHNOLOGY



OPTIONAL



color_ ● ○ ●

2 Uscite Posteriori (2 Motori) - Ventilazione Frontale (1 Motore) - Uscita Fumi Posteriore

2 Rear Outlets (2 Motors) - Front Ventilation (1 Motor) - Rear Exhaust Fume Outlet - 2 Sorties Arrière (2 Moteurs) - Ventilation Avant (1 Moteur) - Sortie De Fumée Arrière - 2 Salidas Traseras (2 Motores) - Ventilación Frontal (1 Motor) - Salida De Humos Trasera - 2 Ausgänge Hinten (2 Motore) - Front Gebläse (1 Motor)

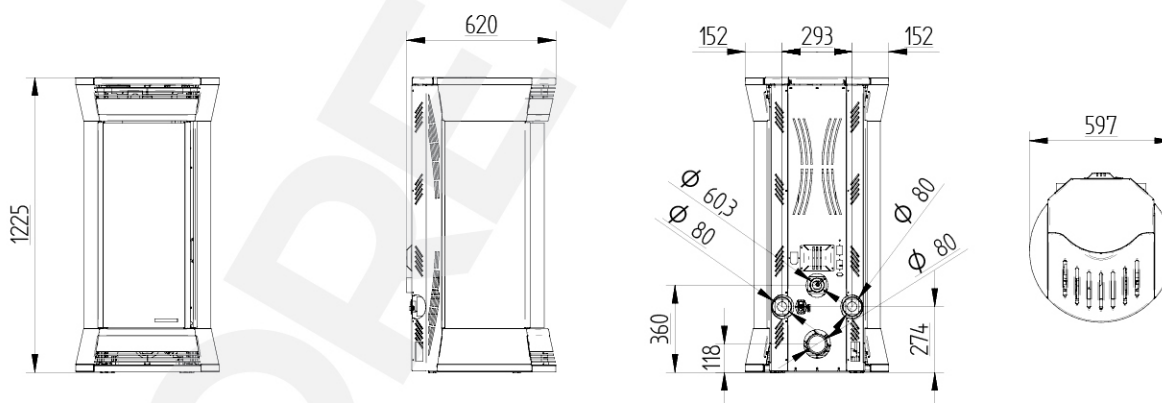

Potenza Globale
Global Power
Puissance globale
Potencia global
Verbrennungsleistung

Rendimento totale
Total efficiency
Puissance globale
Potencia global
Pellet Wirkungsgrad

Peso
Weight
Poids
Gewicht

Consumo min-MAX
Min-Max consumption
Consumation min-MAX
Consumo min-maxi
Min-Maxi verbrauch

Temperatura gas di scianto
Exhaust gas temperature
Température des gaz d'échappement
Temperatura de los gases de escape
Abgasatemperatur

Tiraggio richiesto in funzionamento
Draw required in operation
Dessiner nécessaire en fonctionnement
Dibujar requerido en la operación
Erforderlicher Betriebszug

Uscita fumi
Chimney Output
Sortie conduit de cheminée
Salida conducto de humos
Rauchauslass

Ingresso aria
Air inlet
Entrée d'air
Entrada aire
Luftemlass

Serbatoio pellet
Pellet Tank
Réservoir
Depósito
Tank Fassungsvormögen

Absorbimento elettrico
Electrical consumption
Absorption électrique
Consumo de electricidad
Elektrischer Verbrauch

KW 9,0-24

% 89,2

Kg 161

Kg/H 0,6-2,2

°C 176

Pa 10

mm 80

mm 60

Kg 23

W 100